

JUKI

2-Needle, 3-Thread, Bottom Covering
Stitch Belt-Loop Making Machine

二本針三本糸片面飾りベルトループ縫ミシン

MFB-860

PARTS LIST

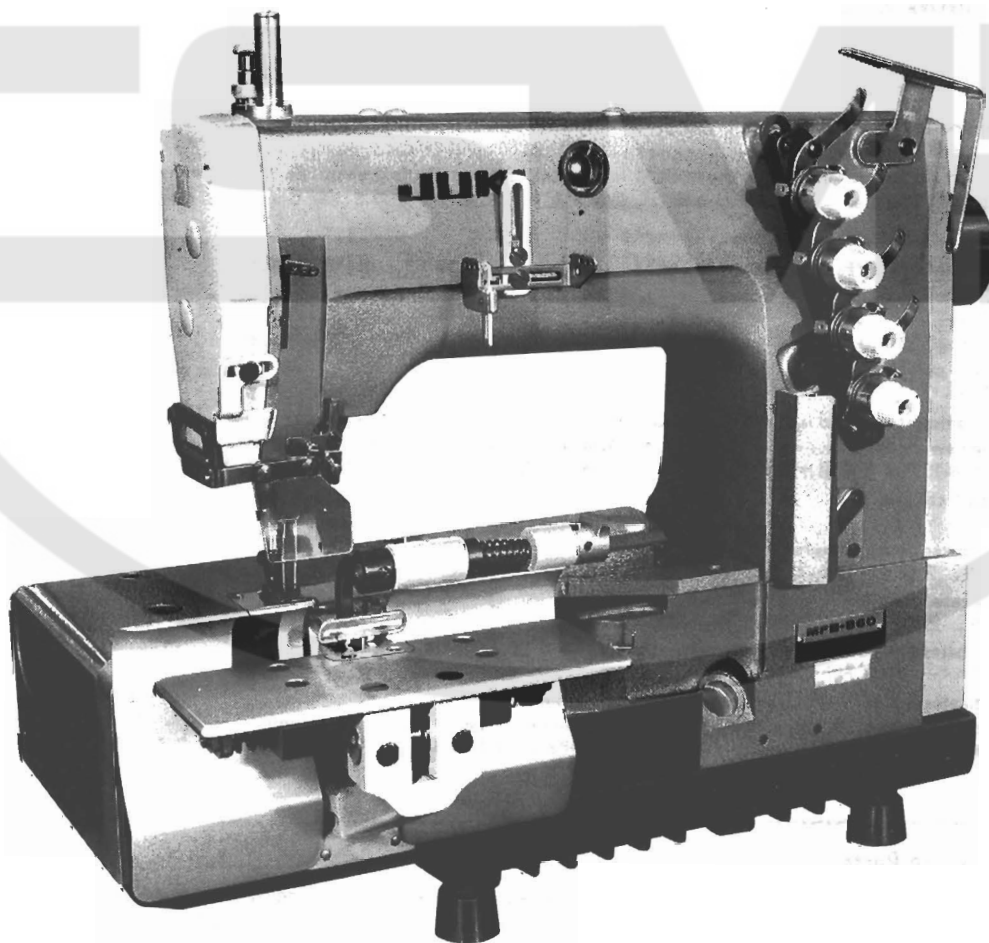

BE860BSOPJA
NO.0087-03

HOW TO MAKE USE OF THIS PARTS LIST

パーツリストの見方

1. The part numbers of parts shown in the figure indicate the corresponding numbers (Ref. No.) shown by the Index.
 図に示された部品の品番は、図にふられているNo (Ref.No)に対応するインデックスによって、その品番がわかります。

2. Explanation of codes 記号の説明

1) Codes on the "Note" column "注記"欄の記号

- ① ☆ means this part is changed from the previous parts list.
前回のパーツリストに対して今回変更された部品を意味します。
- ② #01 refer to the "Note" explanation at bottom of page.
#01 ページ下の"注記"の説明を参照して下さい。

2) Codes on the "E.C. (Engineering change)" column "変更年月"欄の記号

- ① A.10/83 Added from October, 1983
1983年10月より追加された。
- ② D.10/83 Obsoleted from October, 1983
1983年10月より削除された。

③ When previous parts (Obsoleted part) and new parts (Added parts) are not interchangeable with each other: 部品の互換性がない変更の場合

In this case, even obsoleted part (D.) can be ordered with the obsoleted part number, so select the parts with changed dates and place your orders.
 この場合は削除(D)された品番でもご注文できますから、変更年月により、いずれかの部品を選択してご注文下さい。

Example (例)

Ref. No.	Note 注記	Part No. 品番	Description 品名	E.C. 変更年月	Amt. Req. 数量
1	☆	B1401-100-000	Needle bar	D.10/83	-
1-1	☆	B1401-100-000-A	Needle bar	A.10/83	1
2	☆	B1105-200-000	Frame cover	D.10/83	-
	☆	B1105-300-000	Frame cover	A.10/83	1

④ In case when previous parts and new part are interchangeable with each other: 部品の互換性がある場合の変更

In this case the new part number is replaced on the "品名 (Japanese)" column of the previous parts, so please order by the new part number.
 この場合は、旧部品の和文品名欄にそれにかわる新しい品番が記入してありますので、新しい品番でご注文下さい。

⑤ C.10/83

1	☆	B1105-500-000	Frame cover	C.10/83	1
---	---	---------------	-------------	---------	---

↑
Correct No.
正しい品番
↑
Wrong No.
誤り品番

Please order by the correct part number.
正しい品番でご注文下さい。

- ⑥ M.10/83 The amount required is changed from October, 1983
The new amount required is shown in the "Amt. Req". column.
1983年10月より数量が変更になった。この場合数量欄には新しい数量が表示してあります。

3) Codes on the "Amt. Req." column "数量"欄の記号

- ① 2 Indicates amount required is 2.
数量、2個を表わします。
- ② 2.0 Indicates length in meters. (unit is meter)
長さ、2メートルを表わします。(単位はメートルです)
- ③ - Indicates parts obsoleted from the parts list.
このパーツリストから削除された部品です。
- ④ (1) Indicates sub parts which construct the assembly part.
Assembly part is shown as "asm." and クミ in Japanese, in the "Description" column.
組部品を構成している子部品を表わします。組部品は品名欄に英文で "asm." 和文でクミと表示してあります。

When Ordering The Spare Parts:

In order to ensure that we deliver the correct parts to you, please clearly state when ordering the corresponding PART NUMBER (ex. B1109-012-A00) and also the PARTS LIST NUMBER (ex. 0010-01, given at the bottom right of the cover) or the MACHINE SERIAL NUMBER, because there are some parts which have been changed.

補用部品注文の際のご注意

このパーツリストに記載されている補用部品をご注文の際は、部品の番号(例えば、B1109-012-A00)でご注文下さい。合わせて、ご覧のパーツリストの管理番号(表紙右下、例えば、No0010-01)又は、機械番号をご連絡頂ければ幸いです。又、改良のため部品の一部が変更になる場合がありますのでご了承下さい。

CONTENTS

目次

1. UPPER KNIFE & CLOTH FEED COMPONENTS 上メス、布送り関係.....	1
2. LOWER KNIFE & CLOTH PRESSER COMPONENTS 下メス、布押エ関係.....	3
3. FRAME COMPONENTS 頭部関係.....	5
4. TABLE OF GAUGES ゲージ表.....	6
5. TABLE OF FOLDERS バインダー表.....	7
NUMERICAL INDEX OF PARTS 索引.....	8

This PARTS LIST applies to the MFB-860 machine heads labeled with  mark.

このパーツリストは、MFB-860のマーク付き頭部に適用します。

I. UPPER KNIFE & CLOTH FEED COMPONENTS

上メス、布送り関係

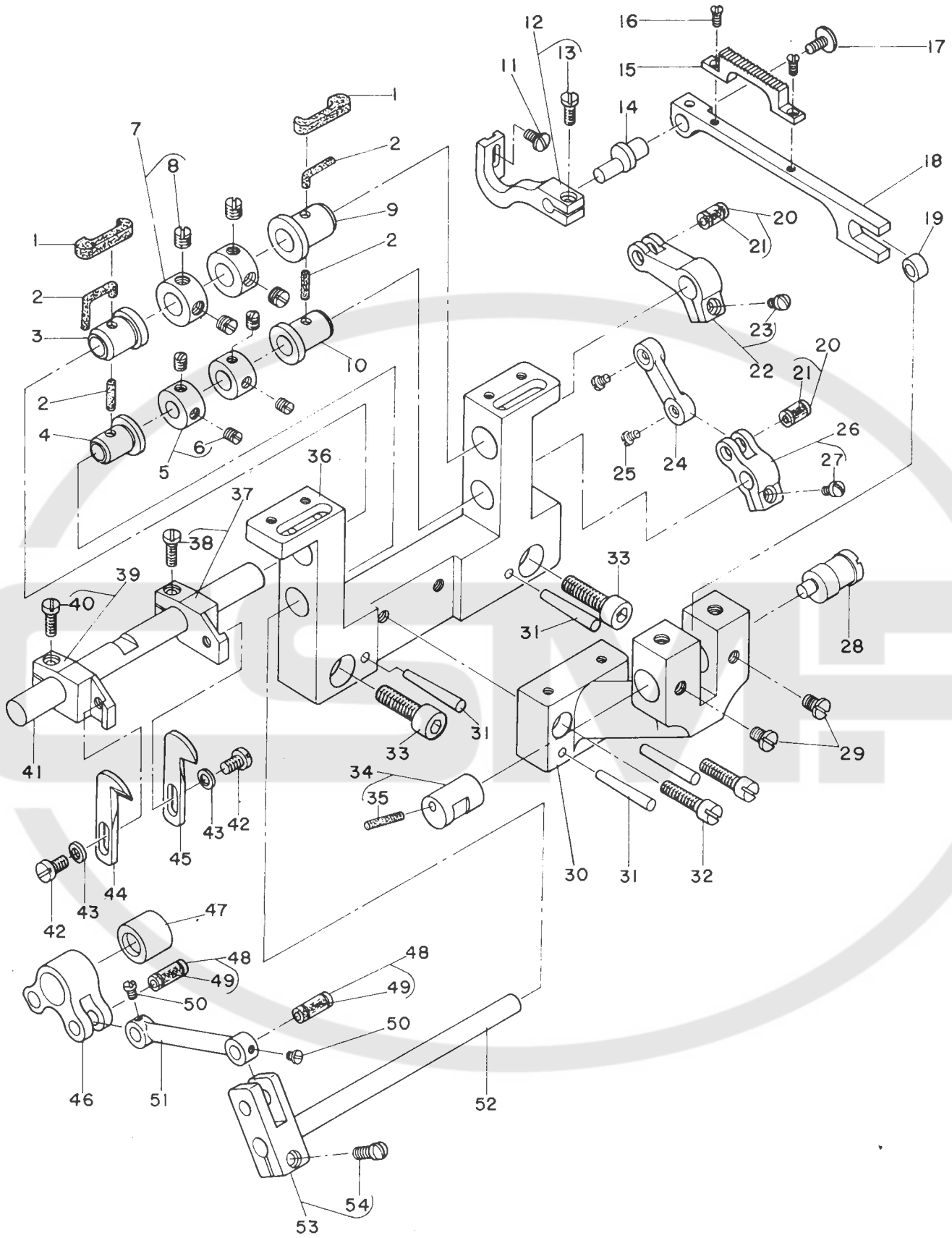

Ref. No.	Note	Part No. 品番	Description	E. C. 変更年月	品名	Amt. Req. 数量
1		MAS-11064000	OIL FELT		アブラタマリ フェルト	2
2		CQ-3000000-F0	OIL FELT		ロツト フェルト	0.1
3		MAS-11003000	UPPER BUSHING, LEFT		ウワメタル (ヒタリ)	1
4		MAS-11005000	LOWER BUSHING, LEFT		シタメタル (ヒタリ)	1
5		CS-079101C-SH	THRUST COLLAR ASM. D=7.94 W=10		スラストワウ D=7.94 W=10 クミ	2
6		SS-8110510-SP	SCREW 11/64-40 L=5		トメネジ 11/64-40 L=5	(4)
7		CS-111101A-SH	THRUST COLLAR ASM. D=11.11 W=10		スラストワウ D=11.11 W=10 クミ	2
8		SS-8660410-TP	SCREW 1/4-40 L=4.2		トメネジ 1/4-40 L=4.2	(4)
9		MAS-11004000	UPPER BUSHING, RIGHT		ウワメタル (ミキ)	1
10		MAS-11006000	LOWER BUSHING, RIGHT		シタメタル (ミキ)	1
11	*	SS-7090850-SP	SCREW 9/64-40 L=8	D.12/79	SS-7090710-SP	-
12	*	SS-7090710-SP	SCREW 9/64-40 L=6.8	A.12/79	メネジ 9/64-40 L=6.8	1
13		MAS-11023080	FEED ARM ASM.		オクリウチ クミ	1
14		SS-7111120-SP	SCREW 11/64-40 L=10.5		メネジ 11/64-40 L=10.5	(1)
15	001	MAS-11025000	FEED PLATE CONNECTING LINK		スノオクリ レンケツシク	1
16		MAS-1103500A	CLOTH FEED A		スノオクリ A	1
17		SS-2090710-SP	SCREW 9/64-40 L=7		メネジ 9/64-40 L=7	2
18		SS-5110710-SP	SCREW 11/64-40 L=7		トラスネジ 11/64-40 L=7	1
19		MAS-11024000	FEED BAR		スノオクリ	1
20		B1611-352-000	DIFFERENTIAL FEED BAR ROLLER		ワウオクリ コ	1
21		MAS-110320A0	PIN ASM.		メス ヨート-リンクピン クミ	2
22		CQ-3000000-F0	OIL FELT		ロツト フェルト	(0.1)
23		MAS-110310A0	FEED ROCKER ARM ASM., UPPER		メス ヨート- ウワロツト クミ	1
24		SS-7110720-SP	SCREW 11/64-40 L=7		メネジ 11/64-40 L=7	(1)
25		MAS-11030000	FEED ROCKER LINK		メスヨート- リンク	1
26		SS-6080410-SP	SCREW 1/8-44 L=4		ヒラネジ 1/8-44 L=4	2
27		MAS-110290A0	FEED ROCKER ARM ASM., LOWER		メス ヨート- シタロツト クミ	1
28		SS-7110720-SP	SCREW 11/64-40 L=7		メネジ 11/64-40 L=7	(1)
29		MAS-11009000	FEED SHAFT		オクリ ウツシク	1
30		SS-7150740-SP	SCREW 15/64-28 L=7		メネジ 15/64-28 L=7	2
31		MAS-11002000	TABLE SUPPORT ARM		チ-フ ウツク	1
32		PT-0403200-SH	TAPERED PIN 4,0X32		チ-ハピン 4X32	4
33		SS-6152440-SP	SCREW 15/64-28 L=23.5		ヒラネジ 15/64-28 L=23.5	2
34		SH-6082502-TM	SCREW M8 L=25		ロツクワナボルト M8 L=25	2
35		MAS-110070A0	REGULATING SHAFT ASM.		チヨ-セツタイ クミ	1
36		CQ-3000000-F0	OIL FELT		ロツト フェルト	(0.1)
37		MAS-11001000	BASE		ト*タイ	1
38		MAS-110110A0	UPPER KNIFE BASE ASM., RIGHT		ウワメス トリツクタイ ミキ クミ	1
39		SS-7111120-SP	SCREW 11/64-40 L=10.5		メネジ 11/64-40 L=10.5	(1)
40		MAS-110100A0	UPPER KNIFE BASE ASM., LEFT		ウワメス トリツクタイ ヒタリ クミ	1
41		SS-7111120-SP	SCREW 11/64-40 L=10.5		メネジ 11/64-40 L=10.5	(1)
42		MAS-11047000	DIFFERENTIAL FEED SHAFT		メス ヲト-シク	1
43	*	SS-7110840-SP	SCREW 11/64-40 L=7.8		メネジ 11/64-40 L=7.8	2
44		WP-0460556-SD	WASHER 4.6X7.5X0.5	D.12/79	WP-0450000-SD	-
45	*	WP-0450000-SD	WASHER 4.5X8X0.5	A.12/79	ヒラネジ 4.5X8X0.5	2
46		MAS-11012000	UPPER KNIFE, LEFT		ウワメス (ミキ)	1
47		MAS-11013000	UPPER KNIFE, RIGHT		ウワメス (ミキ)	1
48		MAS-11028000-A	FEED CRANK LINK		チヨ-セツタイ リンク	1
49		MAS-11069000	NEEDLE BEARING		チヨ-セツタイ ニートル	1
50	002	B2527-860-8A0	PIN ASM.		ヨート-リンクピン クミ	2
51		CQ-3000000-F0	OIL FELT		ロツト フェルト	(0.1)
52		SS-6080410-SP	SCREW 1/8-44 L=4		ヒラネジ 1/8-44 L=4	2
53		MAS-11027000	DRIVING LINK		クト-リンク	1
54		MAS-11048000	FEED ROCKER SHAFT		メス ヨート-シク	1
55		MAS-11026080	DRIVING ARM ASM.		クト-ロツト クミ	1
56		SS-7111410-SP	SCREW 11/64-40 L=14		メネジ 11/64-40 L=14	(1)

Note. (注記) 001. For further details refer to pages 6 & 7.
002. Selecting part

詳しくは、P6、P7を御参照下さい。
選択部品

2. LOWER KNIFE & CLOTH PRESSER COMPONENTS

下メス、布押工関係

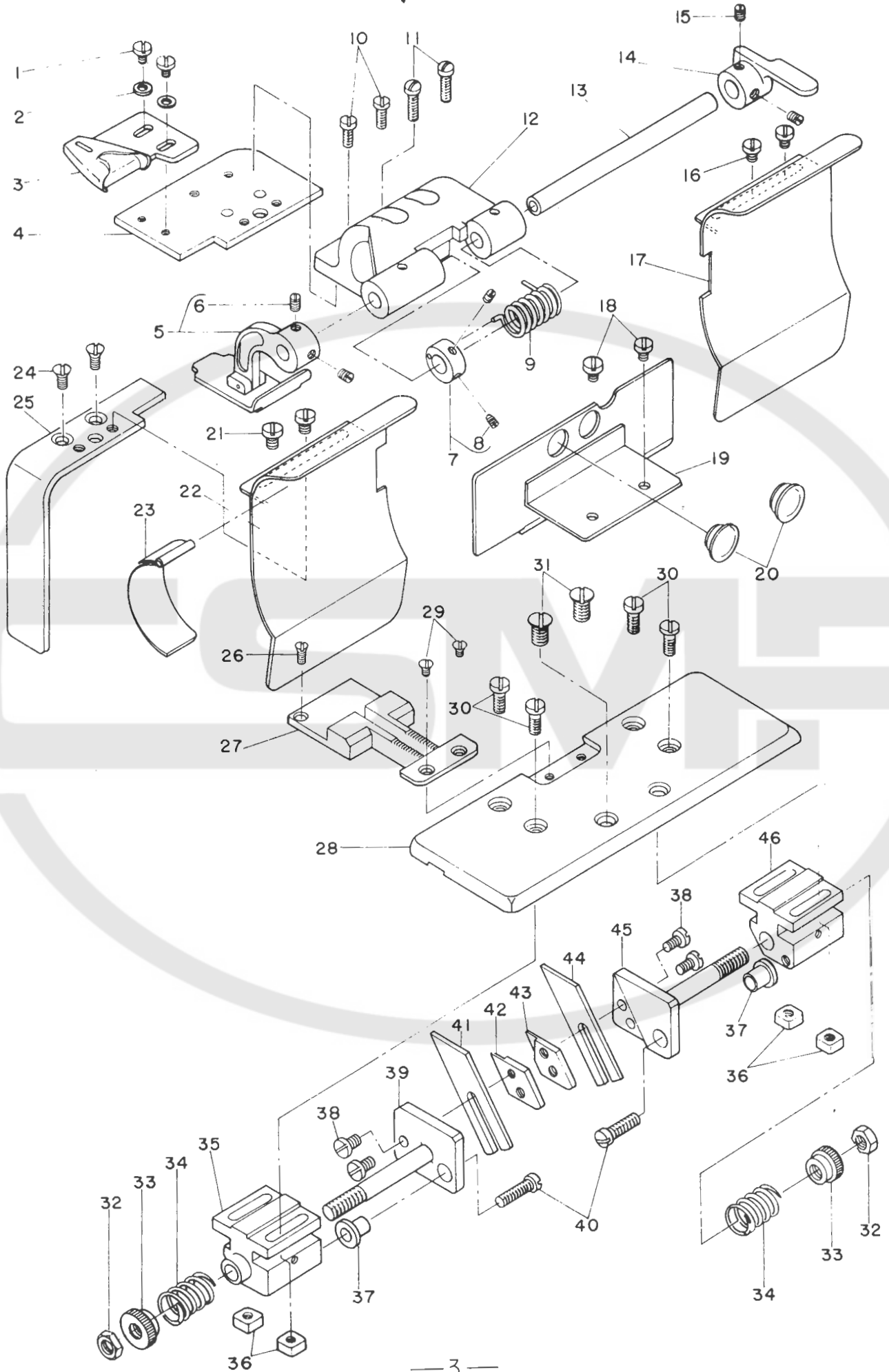

Ref. No.	Note 注記	Part No. 品番	Description	E. C. 変更年月	品名	Amt. Req. 個数
1		SS-7090540-TP	SCREW 9/64-40 L= 5,0		ワシワシ 9/64-40 L= 5	2
2		WP-0450000-SP	WASHER 4,5X8,0X0,5		ヒラワカ 4,5X8,0X0,5	2
3	001	HAS-1100M00B	FOLDER 12MM B		ハインタ 12ミリ (チューアソモノ)	1
4		HAS-11037000	RIGHT COVER		ミキカハ	1
5	001	HAS-110340AM	CLOTH PRESSER ASM. "		スワイ M クス	1
6		SS-8110510-SP	SCREW 11/64-40 L= 5,0		トメシ 11/64-40 L= 5	(2)
7		HAS-110430AO	COLLAR ASM.		ハネトメ クス	1
8		SS-8090540-SP	SCREW 9/64-40 L= 5,0		トメシ 9/64-40 L= 5	(2)
9		HAS-11044000	SPRING		スワイハ	1
10		SS-7111120-SP	SCREW 11/64-40 L=10,5		ワシワシ 11/64-40 L=10,5	2
11		SS-7111410-SP	SCREW 11/64-40 L=14,0		ワシワシ 11/64-40 L=14	2
12		HAS-11038000	PRESSER BASE		スワイグイ	1
13		B2002-038-000	LOOPER ROCKER SHAFT		ルハシク	1
14		HAS-11042000	PRESSER LIFTING LEVER		スワイアア ヲハ	1
15		SS-8110510-SP	SCREW 11/64-40 L= 5,0		トメシ 11/64-40 L= 5	2
16		SS-7110510-SP	SCREW 11/64-40 L= 5,0		ワシワシ 11/64-40 L= 5	2
17		HAS-11046000	CLOTH COVER, RIGHT		スハカ (ミキ)	1
18		SS-7110510-SP	SCREW 11/64-40 L= 5,0		ワシワシ 11/64-40 L= 5	2
19		HAS-11054000	CHIP GUARD COVER		スノカハ	1
20		B1156-850-000	RUBBER PLUG		ムシタ アソ	2
21		SS-7110510-SP	SCREW 11/64-40 L= 5,0		ワシワシ 11/64-40 L= 5	2
22		HAS-11045000	CLOTH COVER, LEFT		スハカ (ヒタリ)	1
23		HAS-11062000	AUXILIARY CLOTH COVER		スハカヨカハ	1
24		SS-2110920-TP	SCREW 11/64-40 L= 8,5		ワシワシ 11/64-40 L= 8,5	2
25		HAS-11036000	LEFT COVER		ヒタリカハ	1
26		SS-2090810-SP	SCREW 9/64-40 L= 7,5		ワシワシ 9/64-40 L= 7,5	1
27	001	HAS-1103300A	FEED PLATE A		スワイタ A	1
28		HAS-11022000	TABLE		チフ	1
29		SS-2090530-SP	SCREW 9/64-40 L= 4,8		ワシワシ 9/64-40 L= 4,8	2
30		SS-6121220-TP	SCREW 3/16-28 L=11,5		ヒタシ 3/16-28 L=11,5	4
31		SS-1681140-SP	SCREW 9/32-28 L=11,0		ワシワシ 9/32-28 L=11	2
32		NS-6680320-SP	NUT 9/32-28		メカナツ 9/32-28	2
33		HAS-11052000	SPRING REGULATOR		ハネ チヨセ	2
34		HAS-11049000	SPRING		メスハ	2
35		HAS-11014000	LOWER KNIFE BASE, LEFT		シタメスク (ヒタリ)	1
36		HAS-11040000	NUT		ツケリツケ ナツ	4
37		HAS-11053000	ROTATION STOPPER		シタメスク マリトメ	2
38		SS-7110840-SP	SCREW 11/64-40 L= 7,8		ワシワシ 11/64-40 L= 7,8	4
39		HAS-11018000	LOWER KNIFE HOLDER, LEFT		シタメ トリツケシク (ヒタリ)	1
40		SS-7111810-SP	SCREW 11/64-40 L=18,0		ワシワシ 11/64-40 L=18	2
41		HAS-11016000	LOWER KNIFE, LEFT		シタメ (ヒタリ)	1
42		HAS-11020000	LOWER KNIFE SET PLATE, LEFT		シタメ トメタ (ヒタリ)	1
43		HAS-11021000	LOWER KNIFE SET PLATE, RIGHT		シタメ トメタ (ミキ)	1
44		HAS-11017000	LOWER KNIFE, RIGHT		シタメ (ミキ)	1
45		HAS-11019000	LOWER KNIFE HOLDER, RIGHT		シタメ トリツケシク (ミキ)	1
46		HAS-11015000	LOWER KNIFE BASE, RIGHT		シタメスク (ミキ)	1

Note. (注記) 001. For further details refer to pages 6 & 7.

詳しくは、P6、P7を御参照下さい。

3. FRAME COMPONENTS

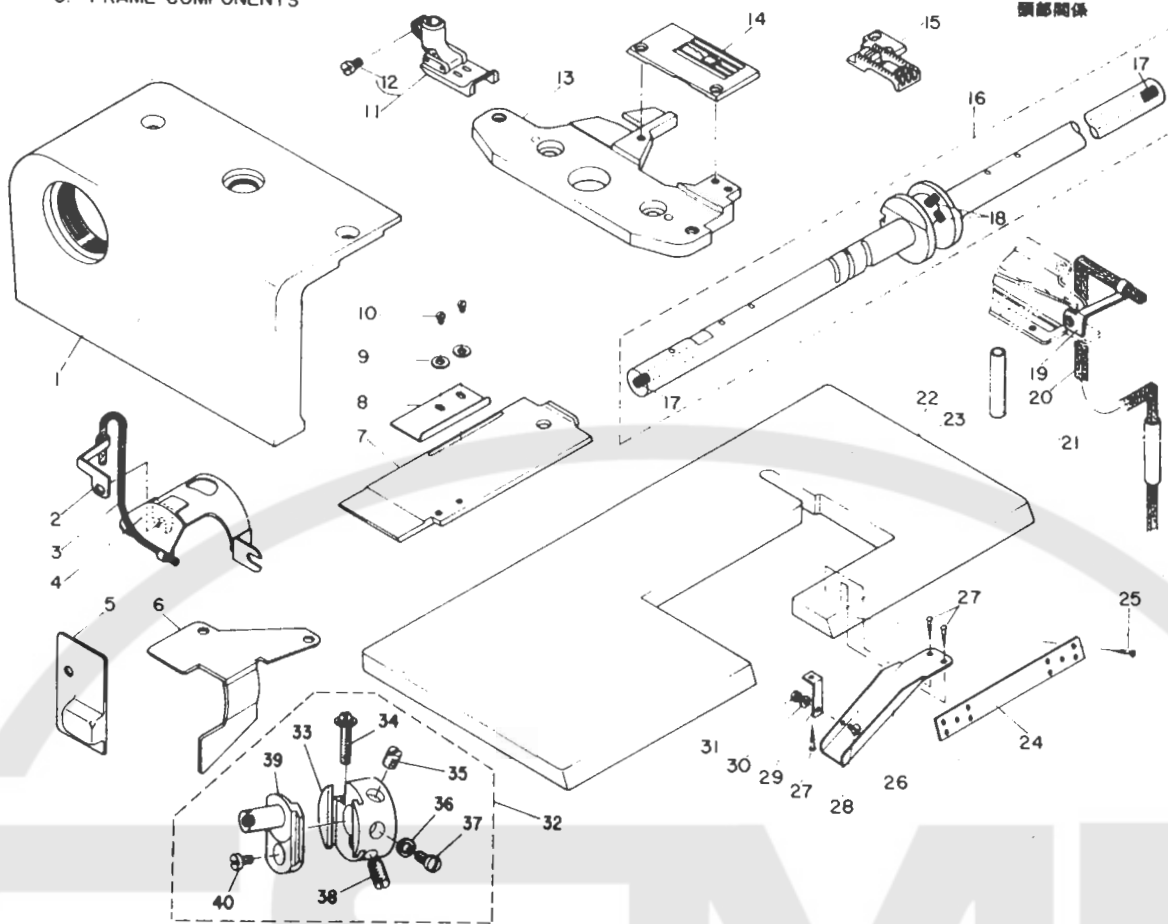

Ref. No.	Note	Part No. 品番	Description	E. C. 変更年月	品名	Amt. Req. 数量
1		MAS-11050000	END COVER		ヘッドカバー	1
2		B3506-761-000	OIL WICK HOLDER		シタカクハクホルダ	1
3		CQ-3000000-F0	OIL FELT		オイルフェルト	0.2
4		MAS-11055000	FEED CAM OIL SHIELD		フィードカムオイルシールド	1
5		MAS-11056000	LOOPER OIL SHIELD, LEFT		ルーパーオイルシールド(左)	1
6		MAS-11067000	LOOPER OIL SHIELD, RIGHT		ルーパーオイルシールド(右)	1
7		MAS-11057000	SLIDE PLATE		スライドプレート	1
8		MAS-11058000	SLIDE PLATE COVER		スライドプレートカバー	1
9		WP-0250516-SD	WASHER 2.5X6X0.5		ワッシャー 2.5X6X0.5	2
10		SS-5060310-SP	SCREW 3/32-56 L=2.8		ボルト 3/32-56 L=2.8	2
11	01	RS212-F0G-0AP	PRESSER FOOT ASM, G12		プレスフットアセンブリ	1
12		SS-6090670-TP	SCREW 9/64-40 L=6		ボルト 9/64-40 L=6	(1)
13		MAS-11051000	THROAT PLATE BASE		ハリスプレートベース	1
14	01	R4253-F0G-G0P	THROAT PLATE (GGB)		ハリスプレート (GGB)	1
15	01	R0000-F0F-40P	FEED DOG (F,G)		フィードドッグ	1
16		MAS-110680A0	LOWER SHAFT ASM.		シャフト	1
17		TA-0500601-H0	PLUG D=5X5.4 L=6		プラグ D=5X5.4 L=6	(2)
18		TA-0290601-H0	PLUG D=2.9X3.2 L=6		プラグ D=2.9X3.2 L=6	(2)
19		B3506-761-000	OIL WICK HOLDER		シタカクハクホルダ	1
20		B3541-012-000	OIL WICK		カンリユ	1
21		B3522-850-000	OIL PIPE		パイプ	2
22	03	B8201-850-00E	TABLE E		テーブル	1
23	04	B8201-850-00F	TABLE F		テーブル	1
24		MAS-11061000	TABLE REINFORCEMENT PLATE		テーブル強化プレート	1
25		SK-1382500-SC	WOOD SCREW D=3.8 L=25		ウッドボルト D=3.8 L=25	10
26		MAS-11059000	CHIP SHUTE		チップシャット	1
27		SK-3482500-SC	WOOD SCREW D=4.8 L=25		ウッドボルト D=4.8 L=25	3
28		SS-5110710-SP	SCREW 11/64-40 L=7		ボルト 11/64-40 L=7	1
29		MAS-11060000	CHIP SHUTE SET PLATE		チップシャットセットプレート	1
30		WP-0480856-SP	WASHER 4.8X8.4X0.8		ワッシャー 4.8X8.4X0.8	1
31		NS-6110310-SP	NUT 11/64-40		ナット 11/64-40	1
32	*	MAS-110750A0	FEED CRANK STUD BODY ASM.	A.05/80	フィードクランクスタッドボディアセンブリ	1
33	*	B1611-850-000	FEED CRANK STUD	A.05/80	フィードクランクスタッド	(1)
34	*	MAS-110760A0	STITCH REGULATING SCREW ASM.	A.05/80	ステッチ調整ボルトアセンブリ	(1)
35	*	SS-8150710-SP	SCREW 15/64-28 L=7	A.05/80	ボルト 15/64-28 L=7	(1)
36	*	WP-0482086-SD	WASHER 4.8X11.5X2.0	A.05/80	ワッシャー 4.8X11.5X2.0	(1)
37	*	SS-7110630-TP	SCREW 11/64-40	A.05/80	ボルト 11/64-40	(1)
38	*	SS-8151150-SP	SCREW 15/64-28 L=10.5	A.05/80	ボルト 15/64-28 L=10.5	(1)
39	*	MAS-11075000	FEED CRANK STUD	A.05/80	フィードクランクスタッド	(1)
40	*	SS-6090640-SP	SCREW 9/64-40 L=6.0	A.05/80	ボルト 9/64-40 L=6.0	(1)

Note. (注記) 001. For further details refer to pages 6 & 7.

003. For clutch motor

004. For needle positioning motor

詳しくは、P.6、P.7を参照下さい。

クラッチモーター用

ストップモーター用

* All parts other than the above are same as those of model MF-860.

上記以外の部品は、MF-860と同じです。

4. TABLE OF GAUGES

ゲージ表

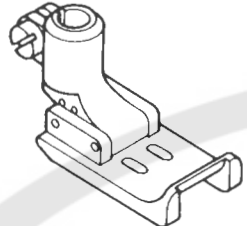
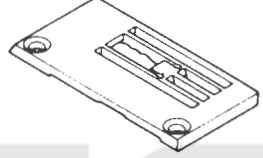
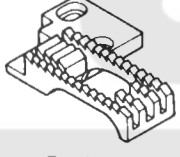
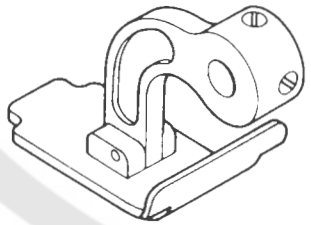
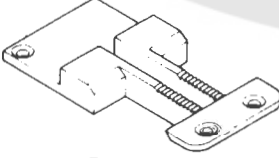
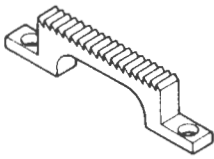
No.	Description 品名	Finished width & Material 仕上り幅 及び厚サ	Needle gauge 針幅		
			F 4.8 mm (3/16")	G 5.6 mm (7/32")	H 6.4 mm (1/4")
1	 Needle clamp asm. 針留(組)		B1409-860-FA0	B1409-860-GA0	B1409-860-HA0
2	 Presser foot asm. 押工(組)	8 mm (5/16")	*R5208-F0F-0AP		
		10 mm (25/64")	R5210-F0F-0AP	R5210-F0G-0AP	R5210-F0H-0AP
		12 mm (15/32")	R5212-F0F-0AP	R5212-F0G-0AP	R5212-F0H-0AP
		15 mm (19/32")		R5215-F0G-0AP	R5215-F0H-0AP
		18 mm (45/64")			*R5218-F0H-0AP
		20 mm (25/32")			*R5220-F0H-0AP
3	 Throat plate 針板	Standard 標準	R4253-F0F-G0P	R4253-F0G-G0P	R4253-F0H-G0P
		Heavy-weight material 厚物		R4250-F0G-J0P	R4250-F0H-J0P
4	 Feed dog 送り歯		R6000-F0F-40P	R6000-F0H-40P	
5	 Cloth presser asm. 布押工(組)	8 mm (5/16")	*MAS-110340AH		
		10 mm (25/64")	MAS-110340AK		
		12 mm (15/32")	MAS-110340AM		
		15 mm (19/32")	MAS-110340AQ		
		18 mm (45/64")	*MAS-110340AT		
		20 mm (25/32")	*MAS-110340AV		
6	 Feed plate 布送り板	14 mm or less (35/64") 14mm以下	MAS-1103300A		
		15 mm or more (19/32") 15mm以上	MAS-1103300B		
7	 Cloth feed 布送り	14 mm or less (35/64") 14mm以下	MAS-1103500A		
		15 mm or more (19/32") 15mm以上	MAS-1103500B		
		12 mm or more (15/32") 12mm以上	MAS-1103500C		

* Special order part 特別注文部品

5. TABLE OF FOLDERS

バインダー表

Type of material 厚サ		Finished width 仕上り幅	H	K	M	Q	T	V
			8 mm (5/16")	10 mm (25/64")	12 mm (15/32")	15 mm (19/32")	18 mm (45/64")	20 mm (25/32")
A	Light-weight material 薄物	Part No. 品番	*MAS-1100H00A	*MAS-1100K00A	*MAS-1100M00A			
B	Medium-heavy weight material 中厚物	Part No. 品番	*MAS-1100H00B	MAS-1100K00B	MAS-1100M00B	*MAS-1100Q00B	*MAS-1100T00B	
H	Heavy-weight material 厚物	Part No. 品番			MAS-1100M00H	MAS-1100Q00H	*MAS-1100T00H	*MAS-1100V00H

* Special order part.

Please consult us for other sizes the listed above.

特別注文部品

上記以外のサイズについても御相談をうけたまわります。

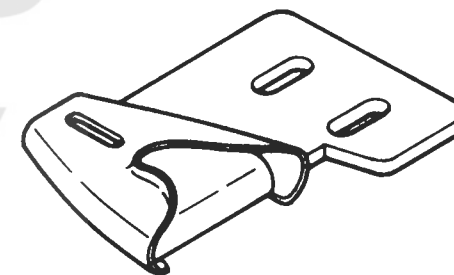

NUMERICAL INDEX OF PARTS

索引

Part No. 品番	Page 頁	Ref. No.	Part No. 品番	Page 頁	Ref. No.	Part No. 品番	Page 頁	Ref. No.	Part No. 品番	Page 頁	Ref. No.
EXCLUSIVE PARTS "B" 専用部品 "B"			MAS-110320A0	2	20	SS-2110920-TP	4	24			
B1156-850-000	4	20	MAS-1103300A	4	27	SS-5060310-SP	5	10			
B1611-352-000	2	19	MAS-110340AM	4	5	SS-5110710-SP	2	17			
B1611-850-000	5	33	MAS-1103500A	2	15	SS-5110710-SP	5	28			
B2002-038-000	4	13	MAS-11036000	4	25	SS-6080410-SP	2	25			
B2527-860-BA0	2	48	MAS-11037000	4	4	SS-6080410-SP	2	50			
B3506-761-000	5	7	MAS-11038000	4	12	SS-6090640-SP	5	40			
B3506-761-000	5	19	MAS-11040000	4	36	SS-6090670-TP	5	12			
B3522-850-000	5	21	MAS-11042000	4	14	SS-6121220-TP	4	30			
B3541-012-000	5	20	MAS-110430A0	4	7	SS-6152440-SP	2	32			
B8201-850-00E	5	22	MAS-11044000	4	9	SS-7090540-TP	4	1			
B8201-850-00F	5	23	MAS-11045000	4	22	SS-7090710-SP	2	11			
OIL WICK			MAS-11046000	4	17	SS-7090850-SP	2	11			
		油心	MAS-11047000	2	41	SS-7110510-SP	4	16			
CQ-3000000-F0	2	2	MAS-11048000	2	52	SS-7110510-SP	4	18			
CQ-3000000-F0	2	21	MAS-11049000	4	34	SS-7110510-SP	4	21			
CQ-3000000-F0	2	35	MAS-11050000	5	1	SS-7110630-TP	5	37			
CQ-3000000-F0	2	49	MAS-11051000	5	13	SS-7110720-SP	2	23			
CQ-3000000-F0	5	3	MAS-11052000	4	33	SS-7110720-SP	2	27			
THRUST COLLAR スラストカラー			MAS-11053000	4	37	SS-7110840-SP	2	42			
CS-079101C-SH	2	5	MAS-11054000	4	19	SS-7110840-SP	4	38			
CS-111101A-SH	2	7	MAS-11055000	5	4	SS-7111120-SP	2	13			
EXCLUSIVE PARTS "M" 専用部品 "M"			MAS-11056000	5	5	SS-7111120-SP	2	38			
MAS-1100M00B	4	3	MAS-11057000	5	7	SS-7111120-SP	2	40			
MAS-11001000	2	36	MAS-11058000	5	8	SS-7111120-SP	4	10			
MAS-11002000	2	30	MAS-11059000	5	26	SS-7111410-SP	2	54			
MAS-11003000	2	3	MAS-11060000	5	29	SS-7111410-SP	4	11			
MAS-11004000	2	9	MAS-11061000	5	24	SS-7111810-SP	4	40			
MAS-11005000	2	4	MAS-11062000	4	23	SS-7150740-SP	2	29			
MAS-11006000	2	10	MAS-11064000	2	1	SS-8090540-SP	4	8			
MAS-110070A0	2	34	MAS-11067000	5	6	SS-8110510-SP	2	6			
MAS-11009000	2	28	MAS-110680A0	5	16	SS-8110510-SP	4	6			
MAS-110100A0	2	39	MAS-11069000	2	47	SS-8110510-SP	4	15			
MAS-110110A0	2	37	MAS-110750A0	5	32	SS-8150710-SP	5	35			
MAS-11012000	2	44	MAS-11075000	5	39	SS-8151150-SP	5	38			
MAS-11013000	2	45	MAS-110760A0	5	34	SS-8660410-TP	2	8			
MAS-11014000	4	35	NUT		ナット	PLUG		止メ栓			
MAS-11015000	4	46	NS-6110310-SP	5	31	TA-0290601-M0	5	18			
MAS-11016000	4	41	NS-6680320-SP	4	32	TA-0500601-M0	5	17			
MAS-11017000	4	44	PIN		ピン	WASHER		座金			
MAS-11018000	4	39	PT-0403200-SH	2	31	WP-0250516-SD	5	9			
MAS-11019000	4	45	EXCLUSIVE PARTS "R" 専用部品 "R"			WP-0450000-SD	2	43			
MAS-11020000	4	42	R4253-F0G-G0P	5	14	WP-0450000-SD	4	2			
MAS-11021000	4	43	R5212-F0G-OAP	5	11	WP-0460556-SD	2	43			
MAS-11022000	4	28	R6000-F0F-40P	5	15	WP-0480856-SP	5	30			
MAS-110230B0	2	12	SCREW		ネジ	WP-0482086-SD	5	36			
MAS-11024000	2	18	SK-1387500-SC	5	25						
MAS-11025000	2	14	SK-3482500-SC	5	27						
MAS-110260B0	2	53	SM-6082502-TM	2	33						
MAS-11027000	2	51	SS-1681140-SP	4	31						
MAS-11028000-A	2	46	SS-2090530-SP	4	29						
MAS-110290A0	2	26	SS-2090710-SP	2	16						
MAS-11030000	2	24	SS-2090810-SP	4	26						
MAS-110310A0	2	22									



JUKI

JUKI CORPORATION

HEAD OFFICE

2-1, 8-CHOME, KOKURYO-CHO,
CHOFU-CITY, TOKYO, JAPAN

BUSINESS OFFICE

23-3, KABUKI-CHO 1-CHOME,
SHINJUKU-KU, TOKYO 160, JAPAN

CABLE : JUKI TOKYO

TELEX : J22967, 232-2301

PHONE : 03(205)1188, 1189, 1190

JUKI 株式会社

〒182 東京都調布市国領町8-2-1

TEL. 03-480-1111(代表)

工業製品販売部

TEL. 03-480-1113(ダイヤルイン)

